

Teacher Resource Guide

Community Center Design
Challenge

The Teacher Resource Guide for the Community Center Design Challenge provides teachers with additional information in order to best implement this activity in the classroom. The Teacher Resource Guide includes ideas for mini- lessons, sample rubrics, explanations, as well as the standards addressed within this activity.

Table of Contents

Topic	Page
NCTM Standards.....	1
Specifications and Constraints.....	2-4
Ideas for Differentiation.....	5
Rubrics.....	6-8
Connection Between Area of the Base and Volume.....	9-11
Surface Area Specification.....	12-13
Three-dimensional Cut-outs.....	14-15

NCTM Standards

The following NCTM standards are addressed within the Community Center Design Challenge: Students should-

- **Analyze characteristics and properties of two- and three-dimensional geometric shapes and develop mathematical arguments about geometric relationships**
 - precisely describe, classify, and understand relationships among types of two- and three-dimensional objects using their defining properties;
 - understand relationships among the angles, side lengths, perimeters, areas, and volumes of similar objects;

- **Use visualization, spatial reasoning, and geometric modeling to solve problems**
 - use two-dimensional representations of three-dimensional objects to visualize and solve problems such as those involving surface area and volume;
 - recognize and apply geometric ideas and relationships in areas outside the mathematics classroom, such as art, science, and everyday life.

Specifications and Constraints

Students should be familiar with the terms “specifications” and “constraints” before attempting to identify the specifications and constraints of this design challenge. If your students are not familiar with the terms, it may be beneficial to teach a mini-lesson focusing on specifications and constraints as well as how to extract them from a design challenge scenario.

Specifications are the things that the solution must do. They are the project requirements. For example, a specification may be that your design must have a perimeter between 100cm and 125cm.

Constraints are the things that limit the solution. Constraints may affect how you meet the specifications. For example, a constraint may be how much money a person is permitted to spend on materials.

The teacher should begin by showing the students a design challenge scenario that includes specifications and constraints. The teacher should model how to extract the specifications and constraints from the scenario, placing an emphasis on the difference between specifications and constraints. Then, the students should extract the specifications and constraints from a few example design challenge scenarios before completing the same task for the Community Center Design Challenge.

Example Design Challenge Scenarios

Example 1

You were just hired by a local family to redesign the first floor of their house. You must draw your plan and then build it. The first floor of the house must contain at least three rooms. Each room must have at least three items of furniture. The perimeter of the first floor must not exceed 125 feet. You can only use material that your teacher approves, and you have 4 class periods to complete this challenge.

Specifications

Must contain at least 3 rooms

Each room must have at least 3 pieces
of furniture

Perimeter can't be more than 125ft

Constraints

Can only use material the teacher approves

4 class periods to complete challenge

Example 2

Principal Morris needs your help! He wants to add a new classroom and lunchroom in the school but cannot think of a design. He has chosen you to help him develop a model that he can use as a guide. The model must be three-dimensional and must have a scale in relation to the actual classroom/lunchroom. You must implement at least two different three-dimensional shapes into your model. You must compute the surface area and volume of your model and show all of your work along with labels. You can only use the materials that are provided for you in the classroom. You must complete this project in three class periods. Your model must also be aesthetically pleasing.

Specifications

- Three dimensional model that must be scaled to the actual classroom/lunchroom
- At least 2 different 3D shapes
- Show surface area and volume along with all work
- Must be aesthetically pleasing

Constraints

- Can only use materials provided
- Must complete within 3 class periods

Ideas for Differentiation

The *Community Center Design Challenge* draws upon many mathematical concepts. Some students may have more difficulty completing the activities within the design portfolio than other students. In order to account for the difficulties that some students may face, it is possible to reduce the amount of specifications.

Teachers may choose to eliminate the surface area specification in the design challenge for the struggling students in the class. These students would still complete all KSBs and create their model skyscraper. They would skip the page in the design portfolio that asks the students to calculate the surface area of the model skyscraper that they created.

For the students in the class who finish tasks quickly and correctly, extension question four allows them to expand on the *Skyscraper Design Challenge*. The students who finish the design portfolio and have additional time can answer extension question 4 in a detailed manner and create their solution to the question posed.

Rubrics

In order to assess the *Community Center Design Challenge*, sample rubrics have been included in this resource guide. Teachers are encouraged to alter the rubrics to best suit their needs.

The teacher rubric should be used upon the completion of the design portfolio and final submission of student work. The peer review rubric should be used by the students in order to assess each other's work. The design portfolio states when this process should take place.

Teachers may want to spend a lesson creating the Peer Review Rubric as a class. This lesson should occur after the completion of the KSBs and Reflection so that the students can give an informed opinion of what they should be held accountable for. Rubrics also may be altered in order to better relate to differentiated design portfolios.

Teacher Rubric

Topic	4	3	2	1	Points Received
Specifications and Constraints	All specifications and constraints are correctly identified and listed in the appropriate columns.	Most specifications and constraints are correctly identified and listed in the appropriate columns.	Some specifications and constraints are correctly identified and listed in the appropriate columns.	Very few specifications and constraints are correctly identified and listed in the appropriate columns.	
Mathematical Computations	All computations are completed correctly and the work is shown.	Most computations are completed correctly and the work is shown.	Some computations are completed correctly and some work may not be shown.	Very few computations are completed correctly and there is little or no work shown.	
Properties of 3D Figures	All properties of each 3D and 2D figure have been correctly listed.	Most properties of each 3D and 2D figure have been correctly listed.	Some properties of each 3D and 2D figure have been correctly listed.	Very few properties of each figure have been correctly listed. Some figures may not have any properties listed.	
Meeting the Specifications	The design that was created met all of the specifications and constraints that were given.	The design that was created met most of the specifications and constraints that were given.	The design that was created met some of the specifications and constraints that were given.	The design that was created met very few of the specifications and constraints that were given.	

Peer Review Rubric

Topic	3	2	1	Points Given
Specifications and Constraints	All specifications and constraints are correctly identified and listed in the appropriate columns.	Some specifications and constraints are correctly identified and listed in the appropriate columns.	Very few specifications and constraints are correctly identified and listed in the appropriate columns.	
Meeting the Specifications	The design that was created met all of the specifications and constraints that were given.	The design that was created met some of the specifications and constraints that were given.	The design that was created met very few of the specifications and constraints that were given.	
Trade-offs and Modifications	All trade-offs and modifications were justified and explained appropriately.	Some trade-offs and modifications were justified and explained appropriately.	Very few trade-offs and modifications were justified and explained appropriately.	

Connection Between Area of the Base and Volume

At the beginning of KSB 3, the directions state that the volume for the extruded figures in the chart can be determined by multiplying the area of the base by the height of the figure. Teachers should complete a mini lesson in order to ensure that students understand this connection.

Teachers should make sure that students understand that the rectangular prism, cylinder, and triangular prism are considered the "extruded figures." The area of the base of these figures can be multiplied by the height of the figure in order to find the volume.

Teachers should also discuss the other three figures in KSB 3. The cone, square base pyramid, and triangle base pyramid have a different connection to the area of the base. Unlike the extruded figures, these figures require you to multiply the area of the base by the height of the figure and then divide by three.

The students should be given examples of similar questions in order for the teacher to ensure that the students understand the connection and how to use the formula.

Example 1 - Extruded Figure

a. Find the area of the parallelogram using the formula given below.

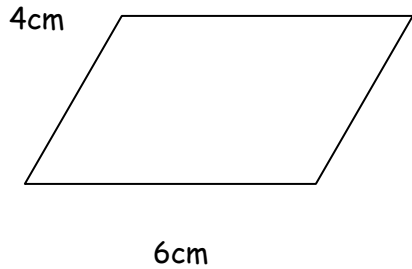

$$A = \text{Base} \times \text{Height}$$

$$A = 6\text{cm} \times 4\text{cm}$$

$$A = 24\text{cm}^2$$

b. Find the volume of the rectangular prism using the formula given below.

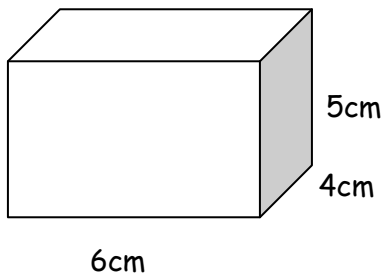

$$V = \text{Area of Base} \times \text{Height}$$

$$V = 24\text{cm}^2 \times 5\text{cm}$$

$$V = 100\text{cm}^3$$

Example 2- Non Extruded Figure

a. Find the area of the circle using the formula given below.

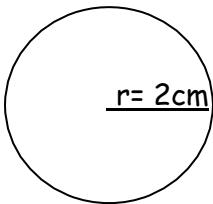

$r =$ radius

$$r^2 = r \times r$$

$$\pi = 3.14$$

$$A = \pi r^2$$

$$r^2 = 2\text{cm} \times 2\text{cm} = 4\text{cm}$$

$$\pi = 3.14\text{cm}$$

$$A = 3.14\text{cm} \times 4\text{cm}$$

$$A = 12.56\text{cm}^2$$

b. Find the volume of the cone using the formula given below.

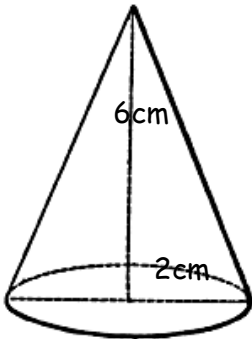

$$V = (\text{Area of Base} \times \text{Height}) \div 3$$

$$V = (12.56\text{cm}^2 \times 6\text{cm}) \div 3$$

$$V = (75.36\text{cm}^3) \div 3$$

$$V = 25.12\text{cm}^2$$

Surface Area Specification

The specification regarding the surface area of the model skyscraper may be difficult for some students to compute. It may be helpful for students to have their model skyscraper in front of them so that they may look at it while doing the computations. Students must remember that the surface area of the model skyscraper only includes the surfaces that are not covered when the skyscraper is standing upright.

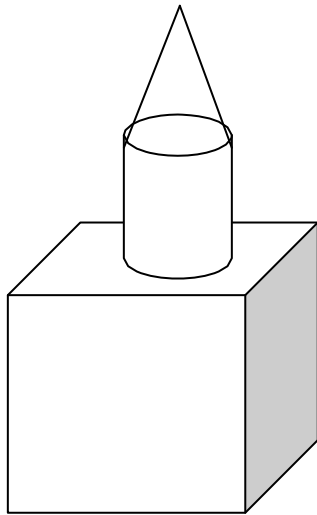

In order to calculate this surface area of this model skyscraper, the base of the cube would not be considered because it is not visible when the skyscraper is standing upright. In addition, both bases of the cylinder as well as the base of the cone would not be considered because they are not visible. Also, the space on the face of the cube that the cylinder is resting on would also not be considered because it is not visible.

Students may find that after doing the calculations, their model skyscraper does not fit the specification for surface area. In order to try to meet the specification, students may choose to get creative with their model. For example, students may take their skyscraper model that looks like the one on the previous page and make it look like the one below. This idea can help decrease the surface area of the model skyscraper in order to help fit the specification.

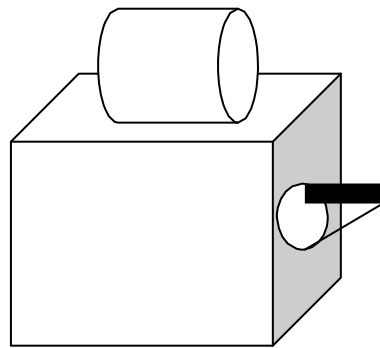

By rotating the cylinder and placing the cone on one of the faces of the cube, the surface area of the skyscraper is altered. The students may then recalculate the surface area and find that they meet the surface area specification. Students should be encouraged to use their creativity in this manner. **This method of altering the skyscraper in order to fit the specification shows a well developed understanding of the concept of surface area.**

Three-dimensional Cut-outs

A page of three-dimensional figures that have been addressed within the design challenge have been included in this resource guide. Students may cut out the figures and paste them in the design portfolio whenever three-dimensional drawing is required. Some students may be able to easily accomplish three-dimensional drawing, while other students may find it to be a much more difficult task. The cut-outs have been included so that students do not find themselves struggling to provide an accurate example of a three-dimensional figure.

Three-dimensional Cut-out Figures

